

# CARBON MONOXIDE ALARM

CAT. **CO400B/CO410B**



## ELECTROCHEMICAL CO SENSOR

Most accurate technology available for detecting carbon monoxide as compared to other sensing technologies.

## BACKLIT DIGITAL DISPLAY (CO410B)

Easily view CO hazard in PPM, peak CO level and other alarm functions.

## TWO SILENCE FEATURES

Silences low battery chirp for up to eight hours or silence nuisance alarm for several minutes.

## END OF LIFE SIGNAL

Provides audible and visual notice when alarm needs to be replaced.

# First Alert®

## 2 AA Battery Powered

The First Alert Cat. Nos. CO400B and CO410B are battery operated, 3V (two 1.5V AA batteries) single station carbon monoxide alarms specifically designed for residential and institutional applications including sleeping rooms of hospitals, hotels, motels, dormitories and other multi-family dwellings as defined in standard NFPA 720. Models CO400 and CO410 comply with UL2034, NFPA 720 and other agencies that model their codes after the above agencies.

First Alert CO400B and CO410B feature an electrochemical CO sensor, an 85dB horn, an End of Life and silence features and a red LED that blinks to indicate unit is receiving power. The front access battery door allows battery access without removing the unit from the wall. The low power warning indicator will cause the alarm to “chirp” when the batteries need replacing. The low power warning indicator can be silenced for up to 8 hours. An Alarm Action Chart identifies action steps to take if unit is in alarm. First Alert CO410B also features a backlit digital display that shows visual confirmation of CO levels and has Peak Level Memory, remembers and displays the highest levels detected when the Peak Level button is pressed. Backlight illuminates only when any button is pressed or unit is in alarm. Includes mounting anchors and screws.



CO400B

CO410B



# CAT. C0400B/C0410B

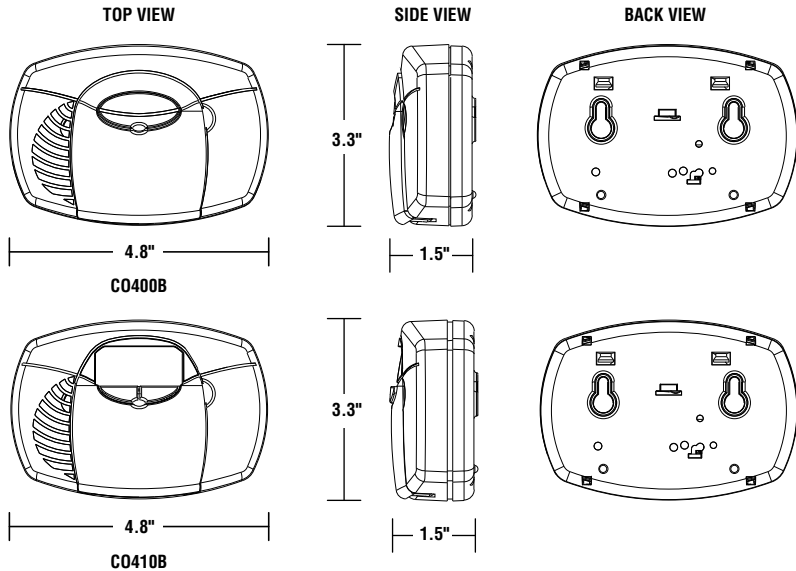

## TECHNICAL SPECS

Alarm Dimensions:	3.3"H x 4.8"L x 1.5"D
Weight:	5.5 oz. (C0400B) 6.2 oz. (C0410B)
Operating Voltage:	Two 1.5V AA Alkaline Batteries
Temperature Range:	40°F (4°C) to 100°F (38°C)
Humidity Range:	10% to 95% relative humidity (RH)
Audio Alarm:	85dB at 10 feet
Test/Silence:	Electronically simulates CO conditions, causing the unit to alarm or temporarily silence the alarm
Alarm Reset:	Automatic when explosive gas and/or CO clears
CO Sensor:	Electrochemical
Indicator Lights/Sounds:	DC Power: Intermittent red Light CO Alarm: Audio Alarm (4 beeps, pause, 4 beeps), rapidly flashing red light
Digital Display:	(C0410B only) Displays battery level, CO levels in parts per million (PPM), Peak CO level
Listing:	Listed to UL 2034 Standard

## ARCHITECTURAL AND ENGINEERING SPEC

The carbon monoxide alarm shall be a First Alert Model C0400 (no display) or a C0410 (digital display) and shall provide at a minimum the following features and functions:

1. An electrochemical CO sensor.
2. The unit shall have a digital display with peak CO memory feature (C0410 only).
3. The unit shall have an "End of Life" signal. This signal should be capable of temporarily being silenced for up to 2 days. After about 2 days, the signal will resume. After about 2-3 weeks the signal cannot be silenced.
4. Powered by supervised 2 AA alkaline batteries and a solid state piezo horn rated at 85dB at 10 ft.
5. The CO sensor is adjusted not to detect CO levels below 30 PPM and will not alarm when exposed to constant levels of 30 PPM for 30 days. It will alarm at the following levels: 400 PPM CO between 4 and 15 minutes, 150 PPM CO between 10 and 50 minutes and 70 PPM CO between 60 and 240 minutes.
6. A visual red LED power-on indicator to confirm unit is receiving power or is in alarm.
7. A full function test button should check all alarm functions by simulating a CO condition, causing the unit to alarm.
8. Two Silence features - Low Battery Silence: Silence low battery chirp for up to 8 hours. Alarm Silence: Temporarily silence unwanted nuisance alarms.
9. The unit shall be capable of operating between 40°F (4°C) and 100°F (38°C) and relative humidity between 10% and 95%.
10. The unit shall contain mounting hardware and shall be listed for wall mounting.
11. The unit shall at a minimum meet the requirements of UL2034, NFPA 720, NFPA 101, ICC.

## SHIPPING SPECS:

Individual Carton Dimensions	5.813 "L x 2.938"W x 3.438"H
Weight	0.43 lbs. (C0400B) 0.48 lbs. (C0410B)
Cube	0.034 ft3
UPC	0 29054 00074 3 (C0400B) 0 29054 00097 2 (C0410B)
Master Carton Dimensions	7.4"L x 5.4"W x 6.1"H
Master Pack	6
Weight	2.92 lbs. (C0400B) 3.21 lbs. (C0410B)
Cube	0.14 ft3
I2 of 5	600 29054 00074 5 (C0400B) 600 29054 00097 4 (C0410B)
Pallet Information	
Cases per Layer	45
Number of Layers	6
Cases per Pallet	270
Units per Pallet	1,620
Cube	49.6 ft3
Weight	788 lbs. (C0400B) 867 lbs. (C0410B)

## INSTALLATION OF ALARM

Installation of this alarm must conform to NFPA 720. Always check your local building codes. Follow all instructions for placement as outlined in the user's manual.

### THE PARTS OF THESE CO ALARMS

**CO400B**

**CO410B**

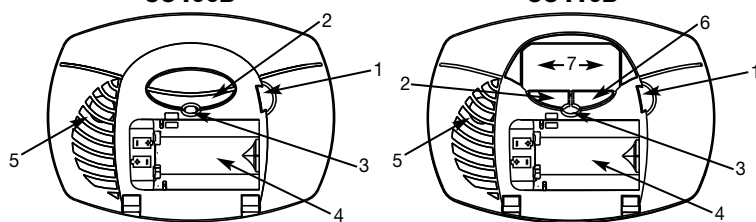

1. Open door here
2. Test/Silence button
3. POWER/ALARM Light
4. AA Battery Compartment
5. (Behind Cover) Alarm Horn
6. Peak Level Button (CO410B only)
7. Digital Display (CO410B only)



©2009 BRK Brands, Inc. a Jarden Corporation  
Company (NYSE: JAH)  
3901 Liberty Street Road  
Aurora, IL 60504-8122  
All rights reserved

First Alert is a registered trademark of the First Alert Trust  
BRK is a registered trademark of BRK Brands, Inc.  
CM2927