

CARBON MONOXIDE ALARM

CAT. **C0600B/C0605B/
C0615B**



(C0605/615 only)

ELECTROCHEMICAL CO SENSOR

Most accurate technology available for detecting carbon monoxide as compared to other sensing technologies.

BACKLIT DIGITAL DISPLAY (C0615B)

Easily view CO hazard in PPM, peak CO level and other alarm functions.

TWO SILENCE FEATURES

Silences low battery chirp for up to eight hours or silence nuisance alarm for several minutes.

END OF LIFE SIGNAL

Provides audible and visual (visual on C0615B only) notice when alarm needs to be replaced.

BATTERY BACKUP

Two AA alkaline battery backup. Models C0605 and C0615 only.

First Alert®

120V AC Plug-in with Two AA Alkaline Battery Backup (C0605B & C0615B)

The First Alert Cat. Nos. C0600B, C0605B and C0615B are direct plug-in, 120V AC, 60Hz single station carbon monoxide alarms specifically designed for residential and institutional applications including sleeping rooms of hospitals, hotels, motels, dormitories and other multi-family dwellings as defined in standard NFPA 720. C0600B, C0605B and C0615B comply with UL2034, NFPA 720 and other agencies that model their codes after the above agencies. C0600B meets codes where plug-in AC carbon monoxide alarms are required. C0605B and C0615B meet codes where plug-in AC/DC carbon monoxide alarms are required. C0615B meets codes where digital display alarms are required.

First Alert C0600B, C0605B and C0615B feature an electrochemical CO sensor, an 85dB horn, an End of Life feature, a single button for test/silence and an LED power indicator. For First Alert C0605B & C0615B battery backup alarms, the front access battery door allows battery access without removing the unit from the wall. The low power warning indicator will cause the alarm to "chirp" when the batteries need replacing. The low power warning indicator can be silenced for up to 8 hours. First Alert C0615B also features a backlit digital display that shows visual confirmation of CO levels and has Peak Level Memory. Light illuminates only when any button is pressed or unit is in alarm. C0600B is designed to be plugged directly into a standard non-switched outlet. C0605 & C0615 can be plugged directly into an outlet or the line cord can be used to mount the unit to the wall away from the outlet. Mounting anchors and screws are included.



C0600B/
C0605B

C0615B



CAT. C0600B/C0600B/C0615B

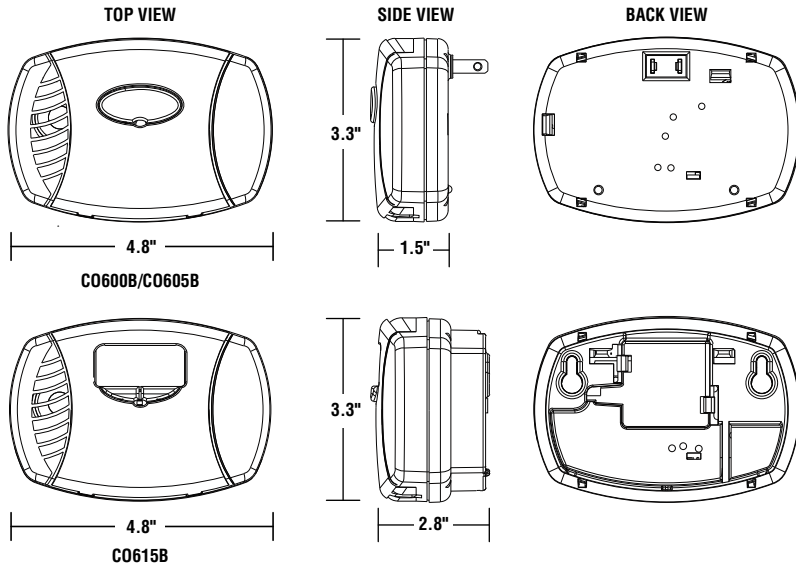

TECHNICAL SPECS

Alarm Dimensions:	3.3"H x 4.8"L x 1.5"D (C0600B) 3.3"H x 4.8"L x 2.1"D (C0605B, C0615B)
Weight:	4.0 oz. (C0600B) 6.6 oz. (C0605B) 7.2 oz. (C0615B)
Operating Voltage:	120V AC 60 Hz Two 1.5V AA Alkaline Battery Backup (C0605B, C0615B)
Temperature Range:	40°F (4°C) to 100°F (38°C)
Humidity Range:	10% to 95% relative humidity (RH)
Audio Alarm:	85dB at 10 feet
Test/Silence:	Electronically simulates CO conditions, causing the unit to alarm or temporarily silence the alarm
Alarm Reset:	Automatic when CO clears
CO Sensor:	Electrochemical
Indicator Lights/Sounds:	AC Power: Constant red light DC Power: Intermittent red light CO Alarm: Audio Alarm (4 beeps, pause, 4 beeps), rapidly flashing red light
Digital Display:	(C0615B only) Displays battery level, CO levels in parts per million (PPM), Peak CO level
Listing:	Listed to UL 2034 Standard

ARCHITECTURAL AND ENGINEERING SPEC

The carbon monoxide alarm shall be a First Alert Model C0600 (no battery backup/no display), a C0605 (battery backup/no display) or a C0615 (digital display/battery backup) and shall provide at a minimum the following features and functions:

1. An electrochemical CO sensor.
2. The unit shall have a digital display with peak CO memory feature (C0615 only).
3. The unit shall have an "End of Life" signal. This signal should be capable of temporarily being silenced for up to 2 days. After about 2 days, the signal will resume. After about 2-3 weeks the signal cannot be silenced.
4. Powered by 120V AC, 60Hz. and a solid state piezo horn rated at 85dB at 10 ft. Models C0605 and C0615 feature a 2 AA battery backup and line cord to allow for multiple placement options.
5. The CO sensor is adjusted not to detect CO levels below 30 PPM and will not alarm when exposed to constant levels of 30 PPM for 30 days. It will alarm at the following levels: 400 PPM CO between 4 and 15 minutes, 150 PPM CO between 10 and 50 minutes and 70 PPM CO between 60 and 240 minutes.
6. A red LED power-on indicator to confirm unit is receiving power or is in alarm.
7. A full function test button should check all alarm functions by simulating a CO condition, causing the unit to alarm.
8. Two Silence features - Low Battery Silence (Excludes C0600): Silence low battery chirp for up to 8 hours. Alarm Silence: Temporarily silence nuisance alarms.
9. The unit shall be capable of operating between 40°F (4°C) and 100°F (38°C) and relative humidity between 10% and 95%.
10. The unit shall at a minimum meet the requirements of UL2034, NFPA 720, NFPA 101, ICC.

SHIPPING SPECS:

Individual Carton Dimensions	5.44 "L x 2.38"W x 3.44"H (C0600B) 5.75 "L x 3.00"W x 2.94"H (C0605B, C0615B)
Weight	0.34 lbs. (C0600B) 0.62 lbs. (C0605B) 0.63 lbs. (C0615B)
Cube	0.024 ft3 (C0600B) 0.029 ft3 (C0605B, C0615B)
UPC	0 29054 00073 6 (C0600B) 0 29054 00072 9 (C0605B) 0 29054 00192 4 (C0615B)
Master Carton Dimensions	7.4"L x 7.4"W x 6.1"H (C0600B) 9.13 "L x 7.13"W x 6.31"H (C0605B, C0615B)
Master Pack	6
Weight	2.33 lbs. (C0600B) 3.68 lbs. (C0605B) 3.90 lbs. (C0615B)
Cube	0.193 ft3 (C0600B) 0.238 ft3 (C0605B, C0615B)
I2 of 5	600 29054 00073 8 (C0600B) 600 29054 00072 1 (C0605B) 600 29054 00192 6 (C0615B)
Pallet Information	
Cases per Layer	30 (C0600B) 27 (C0605B, C0615B)
Number of Layers	6 (C0600B) 7 (C0605B, C0615B)
Cases per Pallet	180 (C0600B) 189 (C0605B, C0615B)
Units per Pallet	1,080 (C0600B) 1,134 (C0605B, C0615B)
Cube	34.8 ft3 (C0600B) 52.0 ft3 (C0605B, C0615B)
Weight	484 lbs. (C0600B) 760 lbs. (C0605B) 802 lbs. (C0615B)

INSTALLATION OF ALARM

Installation of this alarm must conform to NFPA 720. Always check your local building codes. Follow all instructions for placement as outlined in the user's manual.

THE PARTS OF THESE CO ALARMS

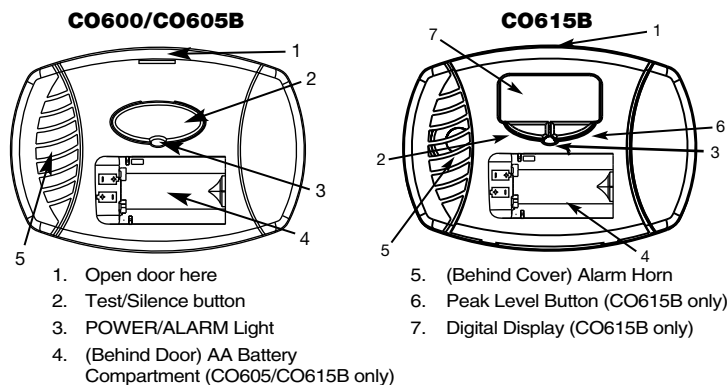

©2009 BRK Brands, Inc. a Jarden Corporation
Company (NYSE: JAH)
3901 Liberty Street Road
Aurora, IL 60504-8122
All rights reserved

First Alert is a registered trademark of the First Alert Trust
BRK is a registered trademark of BRK Brands, Inc.
CM2928